

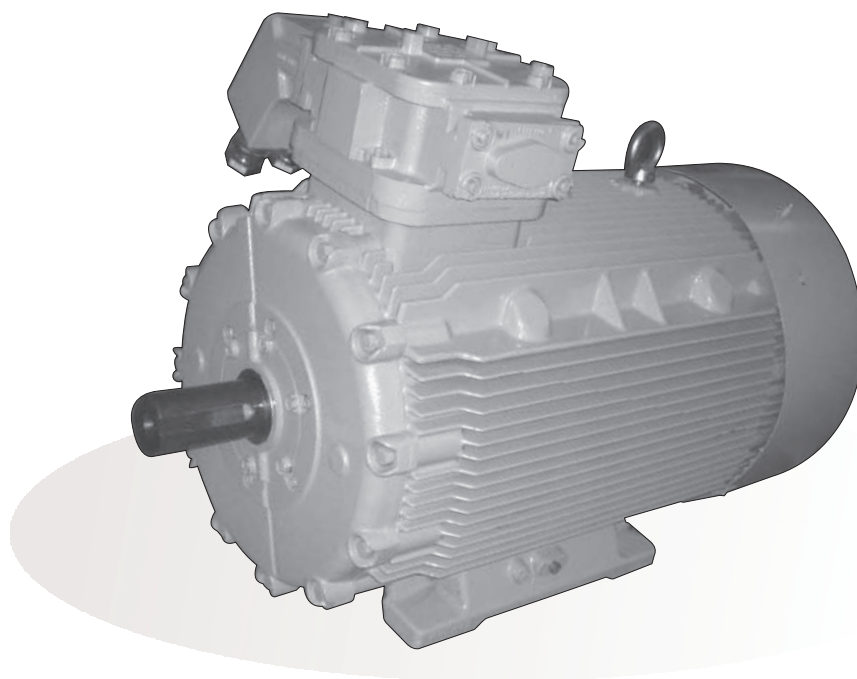

Flame Proof Motors



0.18 kW to 335 kW
From 80 to 355 Frame



THE WIDEST AVAILABLE RANGE

SQUIRREL CAGE MOTORS

0.37 kw to 355 kw (Frames E 80 to E 355 LX)

SLIP RING MOTORS

22 kw to 160 kw
(Frames EW 250 M to EW 315 L)

STANDARD SPECIFICATIONS

- **VOLTAGE** : 415 ± 10%
Other Voltage class (220 V - 660 V)
available on request.
- **FREQUENCY** : 50 ± 5%
25 HZ to 60 HZ available on request.
- Combined variation : ± 10 % (absolute sum)
- **INSULATION** : Class F
Class 'H' can be given on request.
- **RATING/DUTY** : Continuous (S1)
Intermittent duties available on request.
- **MOUNTING** : Horizontal foot mounting (B3)
Other mountings available on request.
- **PAINT** : Epoxy anticorrosive painted surface
(Standard shade 631 as per IS - 5)
- **AMBIENT / TEMPERATURE RISE** :
45⁰C/75⁰C. Higher Amb. upto 60⁰C on request.
- **TEMPERATURE CLASS** : T4
- **DEGREE OF PROTECTION** :
IP 54 - E80 - E132 M
E225 M to E355 LX
(IP55 with canopy can be offered.)
IP55 - Frame E 160L to E 200 L.
- ERTL / CCOE (PESO) / DGMS approvals as a
standard feature. For BASEEFA approval please
contact nearest branch office/works.

APPLICABLE STANDARDS

Enclosure -	IS 2148 EN 50018
Performance -	IS325 BS 5000 (Part 10) IEC60034 -1
Performance for Mines	IS 3682
Dimensions - Foot -	IS 1231 IEC60072-1
Flange -	IS2223 BS4999 Part 414

INDUSTRIAL APPLICATIONS

- Coal Mines.
- Petro Chemicals & Chemicals.
- Oil Mines & Rigs.
- Fertilizers.
- Solvent extraction plants.
- Paints & Varnish Industry.
- LPG Bottling plants.
- Agro Chemicals.
- Drugs & Pharmaceuticals.
- General Industry.

SPECIAL PURPOSE MOTORS FOR

1. Longwall mining equipment.
2. High pressure mine ventilation fans with
plug & socket arrangement.
3. Auxiliary mine ventilation fans with rod
mounting / flange mounting.
4. Belt conveyors and armoured face/ chain
conveyors.
5. Side dump loaders, load haul dumpers
6. Haulages (squirrel cage and slipring motors).
7. Dewatering pumps.
8. Sucker rod pumps.
9. Mud agitators & mud pumps.
10. Slurry extraction pumps.
11. Air compressors & blowers.

SPECIAL DESIGN FEATURES AVAILABLE

1. Dual voltage (550/1100V) with 9 terminal
connections as per NCB 625
2. Non standard voltage and frequency variation
3. Dual voltage (1:2 or 1: $\sqrt{3}$ ratio)
Tripple voltage (1: $\sqrt{3}$: 2 ratio)
4. Energy efficient motors
High slip motors
Motors for frequent starts/stops/reversals
5. 10,12,16,18,24,32 pole motors
6. Special performance requirements
7. Class H insulated motors
8. Low vibration and noise level



9. Special Bearings
10. Tacho mounting
11. Special shaft material
12. Canopy
13. Plug & socket arrangement (30 to 300 Amps, 650 & 1100V) for underground equipments.
14. Flange/foot cum flange /rod mounting.
15. Special RV/RA for slipring motors.
16. Space heaters, thermisters.
17. Multispeed motors.
18. Double /taper/non standard shaft extention
19. Non standard paint shade
20. Motors for use with variable frequency inverter supply

- Separate terminal box for auxiliary terminals (space heaters, thermisters) for frame 225 and above on request.

TERMINAL STUD

- Fully non hygroscopic thermosetting moulded glass filled compound.
- Increased clearances & creepages.
- Anti loosening arrangement.
- Metallic bush insert to take tightening pressure. Eliminates breakage of insulation (E160-315LX frames)

TERMINAL BOX AND TERMINAL ARRANGEMENT





- Cast iron construction, forming a separate flame proof enclosure capable of containing internal explosions.
- Standard position on right hand side viewed from driving end side except in frames E 80, E/EW 315 L & E 355 LX where it is on top.
- Terminal box on top on specific request.
- New terminal box with spigotted cover & gland plate/sealing box in frames E 160 to 355 LX with following advantages.
 - Inherently IP 55.
 - Spaciously designed for accommodating bigger cables.
 - Double decker terminal arrangement for easy termination of two cables.
 - Anti loosening terminal arrangement
- For slipring motors, separate terminal box for stator & rotor terminations provided. Stator terminal box is on left hand side while rotor terminal box is on right hand side, viewed from driving end.
- Conduit plate is provided as standard while sealing box provided for group I gases.

BEARING CHART

FRAME	DE	NDE
E80	6304-2Z	6304-2Z
E90	6205-2Z	6205-2Z
E100	6206-2Z	6206-2Z
E112	6306-2Z	6306-2Z
E132	6308-2Z	6208-2Z
E160	6309-2RS	6309-2RS
E180	6310-2RS	6310-2RS
E200	6312-2RS	6312-2RS
E225	6313-2RS	6313-2RS
E250-2P	6315	6315
E/EW250-4P UP	6315	6315
E280-2P	6315	6315
E/EW280-4P UP	6318	6318
E315-2P	6315	6315
E/EW315-4P UP	6319	6319
E355LX-2p	6316	6316
E355LX-4p UP	6322	6322



STATUTORY APPROVALS

COUNTRY	STATUTORY AUTHORITY	FLAME PROOF NOTATION /MARK		
	SCOPE			
INDIA	ERTL KOLKATA		STANDARD	
	TESTING			
	DGMS DHANBAD			
	APPROVING			
	CCE NAGPUR			
	APPROVING			
	DGFAS & L I MUMBAI			
	APPROVING			
	BIS			
	LICENCE			
UK. ①	BASEEFA		OPTIONAL Requirement to be specified at the time of enquiry / order	
	CERTIFICATE & LICENCE			
	ATEX CE MARK			
	LICENCE			

FLAMEPROOF MOTORS FOR GROUP IIC ATMOSPHERE

A complete range of Crompton Greaves flameproof squirrel cage motors for gas group IIC is now available for Indian Industries as an import substitute. The motors are manufactured as per the most stringent requirements for IIC atmosphere. The motors are duly tested at ERTL.

For more details, please contact our nearest branch office / works.

	ERTL	DGMS	CCE	DGFAS & LI	GROUP SUITABILITY
E 80		—			IIA, IIB ONLY
E 90L					I, II A, II B.
E100L E112 M, E 132 M.					I, IIA, IIB
E160L, E 180 L, E200 L					I, IIA, IIB
E225 S, E 225 M E250 M					I, II A, IIB.
E280 M E315 M/L					I, IIA, IIB.
E355LX		—		—	IIA, IIB.

BASEEFA*	
ATEX	IECEX'd'
√	---
√	---
√	√
√	√
√	√
√	√

AVAILABLE Pending for approval.
 * STANDARD Temperature class T4. Other classes available on request.

* For IIA, IIB Gas Groups

CMRI	: CENTRAL MINING RESEARCH INSTITUTE, DHANBAD.
DGMS	: DIRECTORATE GENERAL OF MINES SAFETY, DHANBAD.
CCE	: CHIEF CONTROLLER OF EXPLOSIVES, NAGPUR.
DGFAS & LI	: DIRECTORATE GENERAL FACTORY ADVICE SERVICE & LABOUR INSTITUTE, MUMBAI.
BIS	: BUREAU OF INDIAN STANDARDS, NEW DELHI.
BASEEFA	: BRITISH APPROVALS SERVICE FOR ELECTRICAL EQUIPMENT IN FLAMMABLE ATMOSPHERES, UK.
ATEX	: EUROPEAN DIRECTIVE
ERTL	: ELECTRONIC REGIONAL TEST LABORATORY

NOTE:* Motors as per UK based standards can be supplied against specific enquiries.



CABLE TERMINATION

CABLE SIZE REFERENCE CHART

FRAME SIZE	MAX. CABLE SIZE				TERMINAL STUD			
	GROUP I - COPPER inch ²		GROUP II - AL. mm ²		MAIN		EARTH	AUX.
	DOL	STAR/DELTA	DOL	STAR/DELTA	NOS.	SIZE	SIZE	SIZE
E 80	NA	NA	4	NA	3	M6	M6	NA
E 90L TO E 132 M	0.25	2 X 0.06	10	2 X 6	6	M6	M6	NA
					3	M6		M6
E 160L TO E 200 L	0.25	2 X 0.06	50 (95 WITH ADAPTOR)	2 X 50	6	M8	M8	M6
E225S TO E315M	0.25	2 X 0.25	185	2 X 120	6	M10	M8	M6
E 315 L & E355	0.25	2X0.25 Double Sealing Box 2X0.06 Single Sealing Box	2 x 3C x 240 Double Sealing Box	2 x 240 Double Sealing Box	6	M14	M8	M8
					3	M16		
EW250 M STATOR ROTOR	0.25	NA	185 95	NA	3	M10	M8	M6
					3	M8		
EW280-EW 315 M STATOR ROTOR	0.25	NA	185 185	NA	3	M10	M8	M6
					3	M10		
EW 315 L STATOR ROTOR	0.25	NA	240 185	NA	3	M16	M8	M8
					3	M10		

NA -Not Available

Note : Motors upto & including 2.2 kw are with 3 leads. 3.7 kw & above are with 6 leads.

Following alternative methods of electrical connections/ cable entry can be provided:

1. CMRI / ERTL approved double compression glands.
2. For group I areas, cable clamps for single/double armoured cable with single/double cone arrangement.
3. Plug and socket arrangement (suitable for 1100 or 650 V) for PATC cables for group I areas. (E 160 L- E 355 LX)
4. Sealing box with entry thread for solid drawn conduit arrangement.

SHIPPING SPECIFICATIONS

FOOT MOUNTING MOTORS					FLANGE MOUNTING MOTORS				
FRAME SIZE	NET WT. KG	GROSS WT. KG	DIMENSIONS LxBxH mm	VOL. CU.M.	FRAME SIZE	NET WT. KG	GROSS WT. KG	DIMENSIONS LxBxH mm	VOL. CU.M.
E80	23	27	345 X 220 X 335	0.025	E80	25	30	345 X 220 X 335	0.025
E90L	40	56	467 X 477 X 319	0.071	E90L	42	70	528 X 362 X 672	0.128
E100L	54	74	507 X 507 X 368	0.095	E100L	56	89	582 X 422 X 687	0.169
E112M	73	102	590 X 532 X 427	0.134	E112M	76	109	582 X 422 X 687	0.169
E132M	110	143	622 X 575 X 427	0.153	E132M	113	156	628 X 472 X 732	0.216
E160L	188	259	875 X 705 X 427	0.36	E160L	215	333	960 X 815 X 815	0.64
E180L	256	362	1025 X 825 X 700	0.59	E180L	260	378	960 X 815 X 815	0.64
E200L	263	369	1025 X 825 X 700	0.59	E200L	300	442	1065 X 885 X 840	0.79
E225S	330	382	1150 X 845 X 710	0.69	E225S	365	510	1065 X 885 X 840	0.79
E225M	400	449	1150 X 845 X 710	0.69	E225M	435	577	1065 X 885 X 840	0.79
E250M	680	818	1300 X 915 X 745	0.89	E250M	705	935	990 X 900 X 1245	1.11
E280M	966	1180	1500 X 1065 X 850	1.36	E280M	1000	1270	1070 X 1070 X 1430	1.64
E315M	1136	1389	1600 X 1170 X 925	1.73	E315M	1180	1508	1280 X 1210 X 1545	2.39
E315L	1752	2105	1830 X 1270 X 1156	2.69	E315L	1800	2214	1850 X 1450 X 1275	3.42
EW250M	740	1015	1730 X 1170 X 865	1.75	EW250M	-	-	-	-
EW280M	1105	1460	2160 X 1220 X 1010	2.66	EW280M	-	-	-	-
EW315M	1300	1645	2160 X 1220 X 1010	2.66	EW315M	-	-	-	-
EW315L	1900	2430	2565 X 1245 X 1120	3.58	EW315L	-	-	-	-
E355LX	2150	2500	2565 X 1245 X 1120	3.58		-	-	-	-



PERFORMANCE FIGURES OF FLP SCR MOTORS FOR 45 AMBIENT 75 DEGREE RISE

OUTPUT		P O L E	FRAME SIZE	FL RPM	FLC AMPS.	EFFICIENCY			POWER FACTOR			DOL STG.		GD SQ. KGM. ²	NET WT KG
KW	HP					FL	3/4 LOAD	1/2 LOAD	FL	3/4 LOAD	1/2 LOAD	STG.T %FLT	STG.C %FLC		
0.18	0.25	2	E80	2850	0.54	64.0	61.0	55.0	0.72	0.68	0.61	250	650	0.003	23
		4	E80	1400	0.55	68.0	64.0	59.0	0.67	0.63	0.57	200	500	0.007	23
		6	E80	950	0.70	58.0	52.0	45.0	0.62	0.52	0.44	220	450	0.011	23
		8	E90L	680	0.84	57.0	52.0	46.0	0.52	0.46	0.40	180	400	0.024	35
0.25	0.33	2	E80	2850	0.68	68.0	64.0	57.0	0.75	0.70	0.62	250	600	0.003	23
		4	E80	1400	0.71	70.0	66.0	59.0	0.70	0.64	0.58	200	500	0.007	23
		6	E80	930	0.89	60.0	54.0	48.0	0.65	0.54	0.48	200	400	0.011	23
		8	E90L	670	1.17	57.0	52.0	46.0	0.52	0.46	0.40	180	400	0.024	38
0.37	0.50	2	E80	2820	0.87	72.0	69.0	63.0	0.82	0.76	0.65	250	550	0.003	23
		4	E80	1410	0.97	72.0	69.0	65.0	0.74	0.7	0.64	225	500	0.007	23
		6	E80	910	1.13	65.0	63.0	59.0	0.7	0.63	0.5	200	400	0.011	23
		8	E90L	680	1.41	64.0	62.0	58.0	0.57	0.5	0.4	170	400	0.024	35
0.55	0.75	2	E80	2820	1.29	73.0	72.0	68.0	0.81	0.73	0.62	250	600	0.003	23
		4	E80	1410	1.32	77.0	74.0	69.0	0.75	0.68	0.58	200	500	0.007	23
		6	E80	910	1.56	69.0	66.0	60.0	0.71	0.63	0.5	200	400	0.011	23
		8	E90L	685	1.69	72.0	68.0	62.0	0.63	0.55	0.42	170	400	0.034	38
0.75	1.00	2	E80	2820	1.72	75.0	73.0	68.0	0.81	0.73	0.6	250	600	0.003	23
		4	E80	1410	1.81	77.0	74.0	69.0	0.75	0.68	0.58	200	500	0.007	23
		6	E90L	925	2.07	72.0	68.0	61.0	0.7	0.62	0.52	180	500	0.024	35
		8	E100L	700	2.26	71.0	67.0	61.0	0.65	0.58	0.45	175	400	0.038	49
1.10	1.50	2	E90L	2830	2.31	78.0	76.0	73.0	0.85	0.79	0.7	230	600	0.010	36
		4	E90L	1415	2.62	77.0	75.0	71.0	0.76	0.7	0.6	200	500	0.018	35
		6	E90L	925	2.95	74.0	69.0	62.0	0.70	0.62	0.52	200	500	0.034	38
		8	E100L	700	3.27	72.0	68.0	61.0	0.65	0.58	0.45	175	400	0.050	51
1.50	2.00	2	E90L	2850	3.11	79.0	77.0	73.0	0.85	0.79	0.7	230	600	0.010	36
		4	E90L	1415	3.34	80.0	79.0	77.0	0.78	0.72	0.65	200	550	0.025	38
		6	E100L	945	3.53	80.0	77.0	71.0	0.74	0.66	0.54	200	500	0.038	49
		8	E112M	715	4.04	76.0	72.0	65.0	0.68	0.6	0.5	170	450	0.130	61
2.20	3.00	2	E90L	2850	4.29	82.0	81.0	79.0	0.87	0.83	0.74	230	600	0.014	39
		4	E100L	1430	4.55	82.0	81.0	78.0	0.82	0.78	0.7	200	600	0.040	49
		6	E112M	945	5.10	80.0	79.0	77.0	0.75	0.7	0.6	200	500	0.106	60
		8	E132M	715	5.38	79.0	78.0	76.0	0.72	0.65	0.55	180	400	0.300	93
3.70	5.00	2	E100L	2850	7.13	84.0	83.0	81.0	0.86	0.82	0.75	250	600	0.029	53
		4	E112M	1430	7.57	84.0	82.0	79.0	0.81	0.78	0.73	200	600	0.099	63
		6	E132M	945	7.57	85.0	84.0	82.0	0.8	0.76	0.72	200	550	0.205	94
		8	E132M	700	8.71	81.0	79.5	77.0	0.73	0.66	0.57	180	400	0.340	98
5.50	7.50	2	E112M	2900	10.38	85.7	84.0	81.0	0.86	0.82	0.76	250	650	0.045	64
		4	E132M	1450	10.59	86.0	85.0	83.0	0.84	0.8	0.71	200	600	0.227	93
		6	E132M	945	11.11	85.0	84.0	82.0	0.81	0.77	0.73	200	500	0.330	98
		8	E160L	710	12.00	85.0	85.0	83.0	0.74	0.7	0.62	150	500	0.460	120
7.50	10.00	2	E132M	2900	13.63	87.0	85.0	82.0	0.88	0.85	0.8	250	650	0.108	98
		4	E132M	1450	14.28	87.0	86.0	85.0	0.84	0.8	0.71	200	600	0.269	98
		6	E160L	970	11.00	87.5	87.0	85.0	0.8	0.76	0.68	175	500	0.46	120
		8	E160L	710	12.00	85.0	85.0	83.0	0.76	0.72	0.64	150	500	0.64	146
9.3	12.5	2	E160L	2920	17	88.0	87.0	85.0	0.88	0.86	0.78	250	600	0.13	260
		4	E160L	1460	17	88.5	88.5	86.5	0.84	0.81	0.73	175	500	0.31	260
		6	E160L	970	18	87.5	87.0	84.0	0.80	0.76	0.68	200	550	0.59	260
		8	E180L	720	20	86.0	86.0	84.0	0.74	0.70	0.60	175	500	0.99	260
11.0	15.0	2	E160L	2920	20	88.5	88.0	86.0	0.88	0.86	0.78	250	600	0.13	260
		4	E160L	1460	21	89.0	89.0	86.0	0.82	0.79	0.70	200	500	0.36	260
		6	E160L	975	22	88.0	87.5	86.0	0.80	0.76	0.68	200	550	0.64	260
		8	E180L	720	24	87.0	87.0	85.0	0.74	0.70	0.60	175	500	1.16	285
15.0	20.0	2	E160L	2920	26	89.5	89.5	87.5	0.88	0.86	0.79	250	650	0.17	260
		4	E160L	1460	27	90.0	90.0	88.0	0.85	0.83	0.75	200	500	0.47	260
		6	E180L	975	29	90.0	90.0	88.0	0.79	0.73	0.66	250	600	1.16	285
		8	E200L	725	33	88.5	88.5	86.5	0.71	0.65	0.55	225	500	2.14	310



PERFORMANCE FIGURES OF FLP SCR MOTORS FOR 45 AMBIENT 75 DEGREE RISE

OUTPUT		P O L E	FRAME SIZE	FL RPM	FLC AMPS.	EFFICIENCY			POWER FACTOR			DOL STG.		GD SQ. KGM. ²	NET WT KG
KW	HP					FL	3/4 LOAD	1/2 LOAD	FL	3/4 LOAD	1/2 LOAD	STG.T %FLT	STG.C %FLC		
18.5	25.0	2	E160L	2920	32	90.0	90.0	88.0	0.88	0.86	0.79	250	650	0.21	260
		4	E180L	1475	34	91.0	91.0	90.0	0.84	0.80	0.72	200	500	0.81	285
		6	E200L	975	34	91.1	91.1	89.9	0.84	0.80	0.70	200	550	1.69	310
		8	E225S	725	39	89.0	88.5	87.0	0.75	0.71	0.63	150	500	3.30	330
22.0	30.0	2	E180L	2940	40	91.0	91.0	89.0	0.84	0.80	0.74	175	500	0.44	285
		4	E180L	1475	40	92.0	92.0	90.0	0.84	0.80	0.72	200	500	0.95	285
		6	E200L	975	40	91.5	91.5	90.1	0.84	0.80	0.70	200	500	2.04	310
		8	E225M	725	46	89.0	88.5	87.0	0.75	0.71	0.63	175	500	3.90	400
30.0	40.0	2	E200L	2950	52	91.5	91.0	89.0	0.87	0.84	0.80	200	600	0.80	310
		4	E200L	1475	53	92.0	92.0	90.5	0.86	0.82	0.76	225	600	1.62	310
		6	E225M	980	53	91.5	91.0	89.5	0.86	0.84	0.80	200	600	3.70	400
		8	E250M	735	63	90.5	87.0	88.5	0.73	0.69	0.61	175	550	7.49	680
37.0	50.0	2	E200L	2960	64	92.5	91.5	89.0	0.87	0.84	0.80	200	500	0.89	270
		4	E225S	1480	63	92.5	92.0	90.5	0.89	0.85	0.77	250	600	2.70	330
		6	E250M	975	65	92.0	91.5	90.0	0.86	0.82	0.74	200	600	7.51	680
		8	E280M	740	75	91.5	91.0	89.5	0.75	0.71	0.63	200	500	14.15	966
45.0	60.0	2	E225M	2955	72	92.5	90.0	88.0	0.94	0.90	0.82	200	650	1.50	400
		4	E225M	1480	76	93.0	92.5	91.0	0.89	0.85	0.77	250	600	3.20	400
		6	E280M	987	78	93.0	92.5	91.0	0.86	0.82	0.74	200	600	14.15	966
		8	E280M	740	91	92.0	91.5	90.0	0.75	0.71	0.63	200	600	14.15	966
55.0	75.0	2	E250M	2980	89	93.0	92.0	90.0	0.92	0.88	0.80	200	600	6.22	680
		4	E250M	1480	93	93.0	92.5	91.0	0.88	0.84	0.76	225	600	6.26	680
		6	E280M	987	96	93.0	92.5	91.0	0.86	0.82	0.74	200	600	14.15	966
		8	E315M	742	108	93.5	93.0	91.0	0.76	0.72	0.62	150	500	24.20	1136
75.0	100.0	2	E280M	2970	121	93.6	93.0	92.0	0.92	0.90	0.86	175	600	7.25	966
		4	E280M	1488	123	93.6	93.0	91.5	0.91	0.88	0.80	200	600	11.60	966
		6	E315M	990	130	93.5	93.0	91.5	0.86	0.82	0.74	200	600	24.20	1136
		8	E315M	742	148	93.0	92.5	91.0	0.76	0.72	0.62	150	500	24.20	1136
90.0	120.0	2	E280M	2970	142	94.0	93.5	91.5	0.94	0.90	0.82	175	600	7.25	966
		4	E280M	1488	147	93.9	93.3	91.8	0.91	0.88	0.84	200	600	11.60	966
		6	E315M	990	155	93.8	93.3	91.8	0.86	0.82	0.74	200	600	24.20	1136
		8	E315L	742	176	93.5	93.0	91.5	0.76	0.72	0.62	150	500	33.33	1752
110.0	150.0	2	E315M	2980	173	94.0	93.0	91.5	0.94	0.90	0.82	175	600	10.76	1136
		4	E315M	1488	180	94.5	93.5	92.0	0.90	0.86	0.78	175	600	20.30	1136
		6	E315L	990	189	94.0	93.5	92.0	0.86	0.82	0.74	200	600	40.00	1752
		8	E315L	742	210	93.5	93.0	91.5	0.78	0.74	0.66	150	500	40.00	1752
132.0	180.0	2	E315M	2980	207	94.5	93.0	91.5	0.94	0.90	0.82	175	600	10.76	1136
		4	E315M	1488	215	94.7	93.5	92.0	0.90	0.86	0.78	175	600	20.30	1136
		6	E315L	990	227	94.0	93.5	92.0	0.86	0.82	0.74	200	600	33.33	1752
		8	E355LX	740	263	94.5	94.5	92.5	0.74	0.70	0.60	150	500	31.80	2500
160.0	215.0	2	E315L	2980	250	94.8	93.5	92.0	0.94	0.90	0.82	175	600	16.37	1752
		4	E315L	1490	260	95.0	94.0	92.5	0.90	0.86	0.78	175	600	24.97	1752
		6	E315L	990	274	94.5	94.0	92.5	0.86	0.82	0.74	200	600	40.00	1752
		8	E355LX	743	304	95.0	94.0	92.0	0.77	0.73	0.63	140	500	36.80	2500
180.0	240.0	2	E315L	2980	280	95.0	94.5	92.5	0.94	0.90	0.82	175	600	16.37	1752
		4	E315L	1488	292	95.3	95.3	94.0	0.90	0.88	0.84	175	600	24.97	1752
		6	E355LX	990	307	95.0	94.5	93.0	0.86	0.82	0.76	140	500	33.50	2500
		8	E355LX	743	335	94.5	94.5	92.0	0.79	0.75	0.67	125	400	51.10	2500
200.0	270.0	2	E315L	2980	317	94.5	94.0	92.5	0.93	0.90	0.82	175	600	16.37	1752
		4	E315L	1488	324	94.5	94.0	92.5	0.91	0.88	0.84	200	650	31.10	1752
		6	E355LX	990	349	95.0	95.0	93.5	0.84	0.81	0.72	130	500	29.70	2500
		8	E355LX	743	371	95.0	95.0	94.0	0.79	0.75	0.66	110	400	58.10	2500
225.0	300.0	2	E355LX	2975	352	95.5	95.5	94.0	0.93	0.90	0.84	150	600	18.40	2500
		4	E355LX	1488	356	95.5	95.5	93.5	0.92	0.88	0.84	150	600	28.00	2500
		6	E355LX	991	390	95.5	95.0	94.0	0.84	0.80	0.70	130	500	31.70	2500



PERFORMANCE FIGURES OF FLP SCR MOTORS FOR 45 AMBIENT 75 DEGREE RISE

OUTPUT		P O L E	FRAME SIZE	FL RPM	FLC AMPS.	EFFICIENCY			POWER FACTOR			DOL STG.		GD SQ. KGM. ²	NET WT KG
KW	HP					FL	3/4 LOAD	1/2 LOAD	FL	3/4 LOAD	1/2 LOAD	STG.T %FLT	STG.C %FLC		
250.0	335.0	2	E355LX	2970	387	95.5	94.8	93.3	0.94	0.92	0.88	150	650	27.70	2500
		4	E355LX	1488	395	95.7	95.2	93.8	0.92	0.88	0.84	150	600	29.60	2500
		6	E355LX	990	434	95.5	95.0	94.0	0.84	0.80	0.70	130	500	35.60	2500
275.0	370.0	2	E355LX	2980	435	95.5	94.8	93.3	0.92	0.90	0.86	150	600	27.70	2500
		4	E355LX	1490	440	95.5	95.0	93.3	0.91	0.88	0.81	140	650	31.60	2500
		6	E355LX	990	477	95.5	95.0	94.0	0.84	0.80	0.74	160	500	39.80	2500
315.0	425.0	2	E355LX	2980	499	95.5	94.8	92.5	0.92	0.90	0.86	175	600	29.60	2500
		4	E355LX	1490	502	96.0	95.1	93.6	0.91	0.88	0.82	140	650	35.50	2500
335.0	452.0	2**	E355LX	2980	530	95.5	94.8	92.5	0.92	0.90	0.88	175	600	29.60	2500
		4	E355LX	1490	534	96.0	95.4	93.8	0.91	0.88	0.82	175	600	39.70	2500

FL = Full Load; FLC = Full Load Current; FLT = Full Load Torque
 SGT. T = Starting Torque; SGT. C = Starting Current
 NOTE : All performance figures are subject to tolerances as per IS 325 - 1996
 **40/80



OUTLINE DIMENSION DRAWING FOR 3 PHASE SQUIRREL CAGE TEFC FOOT MOUNTED TB ON TOP FLAME PROOF INDUCTION MOTORS (FRAME:E80)

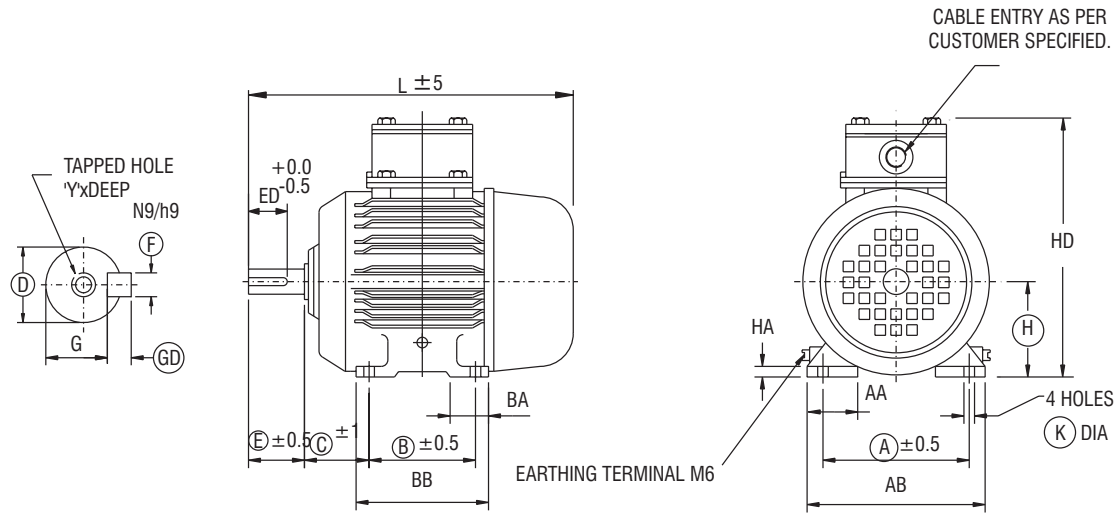

RINGED DIMENSIONS ARE AS PER IS:1231
ALL DIMENSIONS ARE IN mm

Frame	A	B	C	H	AA	AB	BA	BB	K	D	E	ED	F	GD	G	Y	AC	L	HD	HA
E80	125	100	50	80.0 / 79.5	28	152	25	124	10.0 / 10.5	19.009 / 18.996	40	27	6.00 / 5.97	6.00 / 5.97	15.5 / 15.3	M6X16	165	274	268	11

OUTLINE DIMENSION DRAWING FOR 3 PHASE SQUIRREL CAGE TEFC FOOT MOUNTED TB ON RHS FLAME PROOF INDUCTION MOTORS

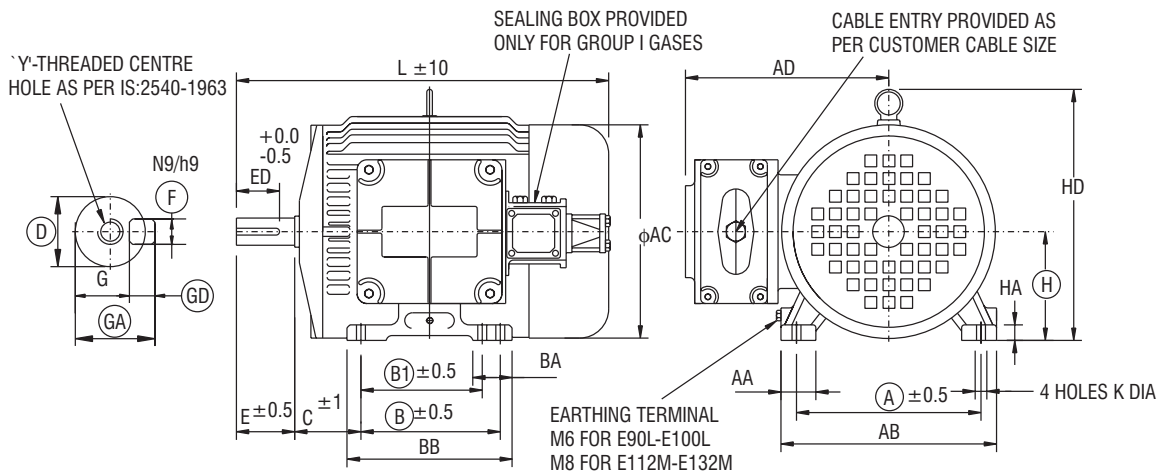

RINGED DIMENSIONS ARE AS PER IS:1231
ALL DIMENSIONS ARE IN mm

Frame	A	B	C	H	AA	AB	BA	BB	K	D	E	ED	F	GD	G	Y	AD	AC	L	HD	HA
E90L	140	125	56	90.0 / 89.7	35	168	45	152	10.5 / 10.0	24.009 / 23.996	50	36	8.00 / 7.957	7.00 / 6.91	20.0 / 19.8	M8x19	240	210	335	195	13
E100L	160	140	63	100.0 / 99.7	38	198	51	170	12.5 / 12.0	28.009 / 27.996	60	44	8.00 / 7.957	7.0 / 6.91	24.0 / 23.8	M10X22	255	240	380	220	13
E112M	190	140	70	112.0 / 111.7	38	228	60	171	12.5 / 12.0	28.009 / 27.996	60	44	8.00 / 7.957	7.0 / 6.91	24.0 / 23.8	M10X22	265	270	400	245	14
E132M	216	178	89	132.0 / 131.7	48	254	64	216	12.5 / 12.0	38.018 / 38.002	80	60	10.0 / 9.957	8.0 / 7.91	33.0 / 32.8	M12X28	285	320	500	290	16



OUTLINE DIMENSION DRAWING FOR 3 PHASE SQUIRREL CAGE TEFC FOOT MOUNTED TB RHS FLAME PROOF INDUCTION MOTORS (4 POLE & UP FOR ALL FRAMES 2 POLE & UP TO ND200L FRAMES)

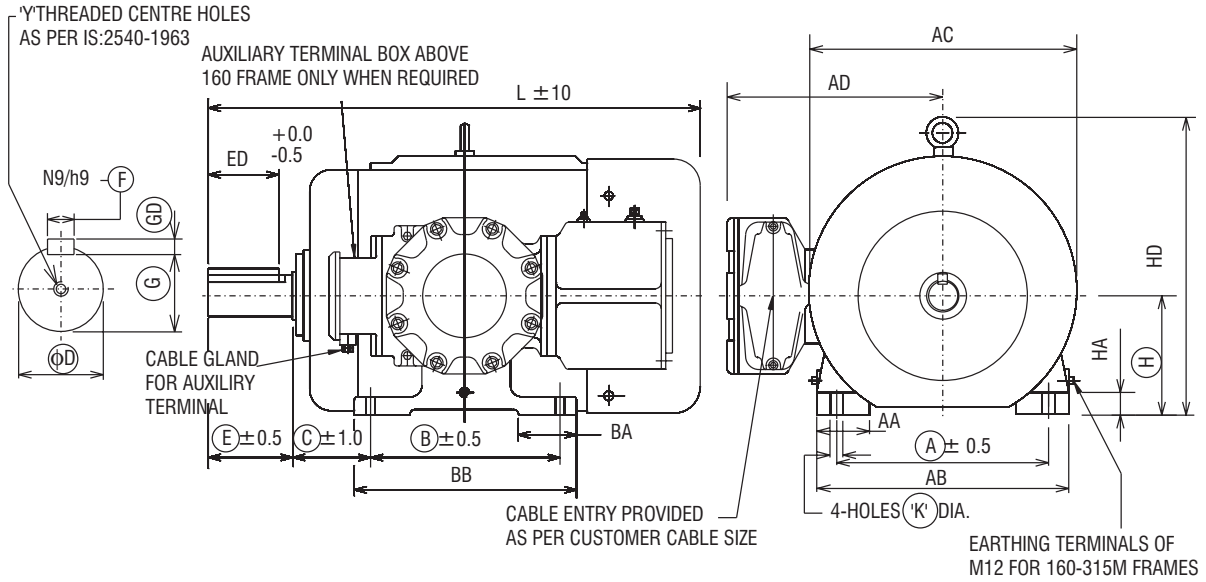

RINGED DIMENSIONS ARE AS PER IS:1231
ALL DIMENSIONS ARE IN mm

Frame	A	B	B1	C	H	AA	AB	BA	BB	K	D	E	ED	F	GD	G	Y	AD	AC	L	HD	HA
4 POLE & UP																						
E160L	254	254	210	108	160.0 / 159.7	54	298	101	298	15.5 / 15.0	42.018 / 42.002	110	80	12.00 / 11.957	8.00 / 7.91	37.0 / 36.8	M16X32	345	320	655	376	22
E180L	279	279	241	121	180 / 179.7	60	337	107	323	15.5 / 15.0	48.018 / 48.002	110	80	14.00 / 13.957	9.00 / 8.91	42.5 / 42.3	M16X32	362	370	725	418	22
E200L	318	305	-	133	200.0 / 199.5	66	381	105	356	19.5 / 19.0	55.030 / 55.011	110	80	16.00 / 15.957	10.00 / 9.91	49.0 / 48.8	M20X40	400	435	790	480	25
E225S	356	286	-	149	225.0 / 224.5	70	425	114	349	19.5 / 19.0	60.030 / 60.011	140	110	18.00 / 17.957	11.00 / 10.91	53.0 / 52.8	M20X40	402	490	832	525	25
E225M	356	311	-	149	225.0 / 224.5	70	425	114	375	19.5 / 19.0	60.030 / 60.011	140	110	18.00 / 17.957	11.00 / 10.91	53.0 / 52.8	M20X40	402	490	857	525	25
E250M	406	349	-	168	250.0 / 249.5	90	483	160	419	24.5 / 24.0	65.030 / 65.011	140	110	18.00 / 17.957	11.00 / 10.91	58.0 / 57.8	M20X40	440	560	977	605	32
E280M	457	419	368	190	280.0 / 279.0	95	540	155	489	24.5 / 24.0	75.030 / 75.011	140	110	20.00 / 19.948	12.00 / 11.91	67.5 / 67.3	M20X40	476	620	1094	660	38
E315M	508	457	-	216	315.0 / 314.0	100	597	190	533	28.5 / 28.0	80.030 / 80.011	170	140	22.00 / 21.948	14.00 / 13.91	71.0 / 70.8	M20X40	516	705	1220	775	38



OUTLINE DIMENSION DRAWING FOR 3 PHASE SQUIRREL CAGE TEFC FOOT MOUNTED TB RHS FLAME PROOF INDUCTION MOTORS (FOR 2 POLE)

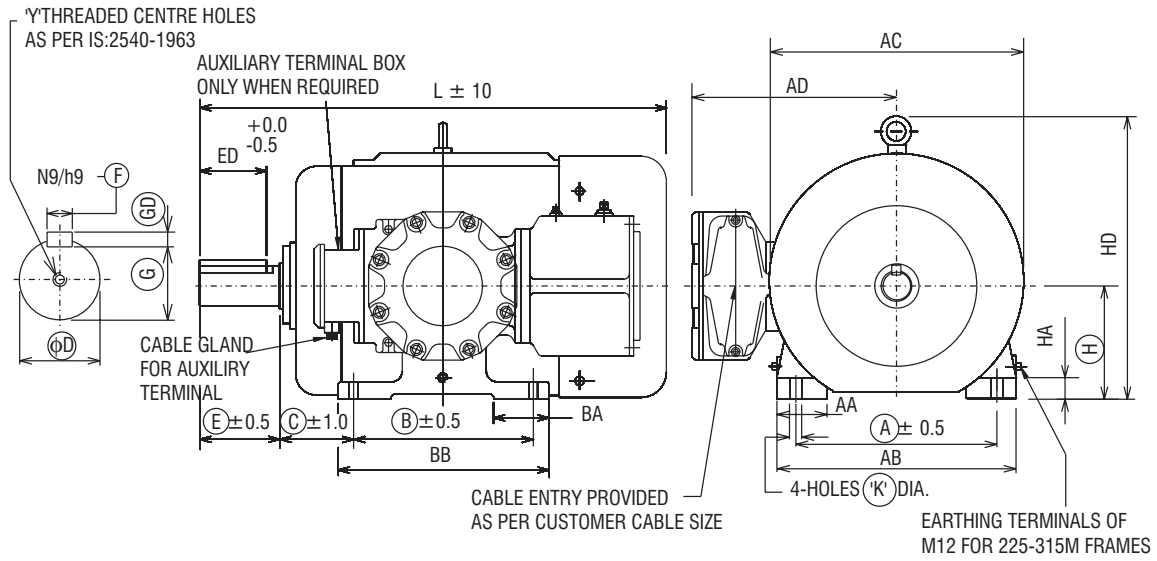

RINGED DIMENSIONS ARE AS PER IS:1231
ALL DIMENSIONS ARE IN mm

Frame	A	B	B1	C	H	AA	AB	BA	BB	K	D	E	ED	F	GD	G	Y	AD	AC	L	HD	HA
E225S	356	286	-	149	225.0/ 224.5	70	425	114	349	19.5/ 19.0	55.030/ 55.011	110	80	16.00/ 15.957	10.0/ 9.91	49.0/ 48.8	M20X40	402	490	802	525	25
E225M	356	311	-	149	225.0/ 224.5	70	425	114	375	19.5/ 19.0	55.030/ 55.011	110	80	16.00/ 15.957	10.0/ 9.91	49.0/ 48.8	M20X40	402	490	827	525	25
E250M	406	349	311	168	250.0/ 249.5	90	483	160	419	24.5/ 24.0	60.030/ 60.011	140	110	18.00/ 17.957	11.00/ 10.91	53.0/ 52.8	M20X40	440	560	977	605	32
E280M	457	419	368	190	280.0/ 279.0	95	540	155	489	24.5/ 24.0	65.030/ 65.011	140	110	18.00/ 17.957	11.00/ 10.91	58.0/ 57.8	M20X40	476	620	1094	660	38
E315M	508	457	-	216	315.0/ 314.0	100	597	190	533	28.5/ 28.0	65.030/ 65.011	140	110	18.00/ 17.957	11.00/ 10.91	58.0/ 57.8	M20X40	516	705	1190	775	38



OUTLINE DIMENSION DRAWING FOR 3 PHASE SQUIRREL CAGE TEFC FOOT MOUNTED FLAME PROOF TB ON TOP INDUCTION MOTORS (FRAME E315L & E355LX)

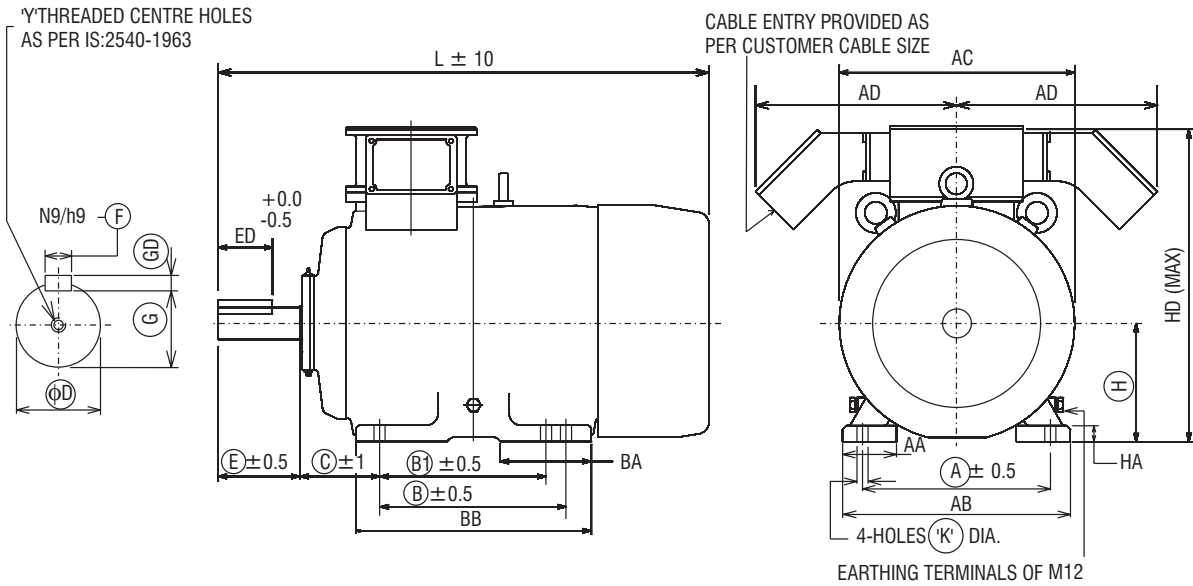

RINGED DIMENSIONS ARE AS PER IS:1231
ALL DIMENSIONS ARE IN mm

Frame	A	B	B1	C	H	AA	AB	BA	BB	K	D	E	ED	F	GD	G	Y	AC	L	HD	HA	AD
2 POLE																						
E315L	508	508	-	216	315.0/ 314.0	100	610	204	655	28.5/ 28.0	70.030/ 70.011	140	110	20.0/ 19.948	12.0/ 11.91	62.5/ 62.3	M20X40	655	1350	875	38	480
E355LX	610	630	560	254	355.0/ 354.0	110	710	250	880	28.5/ 28.0	75.030/ 75.011	170	140	20.00/ 19.948	12.00/ 11.91	67.5/ 67.3	M24x50	720	1540	1005	40	600
4 POLE & UP																						
E315L	508	508	-	216	315.0/ 314.0	100	610	204	655	28.5/ 28.0	90.035/ 90.013	170	140	25.0/ 24.948	14.00/ 13.91	81.0/ 80.08	M24X50	655	1380	875	38	480
E355LX	610	630	560	254	355.0/ 354.0	110	710	290	880	28.5/ 28.0	100.035/ 100.013	210	160	28.00/ 27.948	16.00/ 15.89	90.0/ 89.8	M24x50	720	1580	1005	40	600



OUTLINE DIMENSION DRAWING FOR 3 PHASE SQUIRREL CAGE TEFC FLANGE MOUNTED FLAME PROOF INDUCTION MOTORS (FRAME:E80)

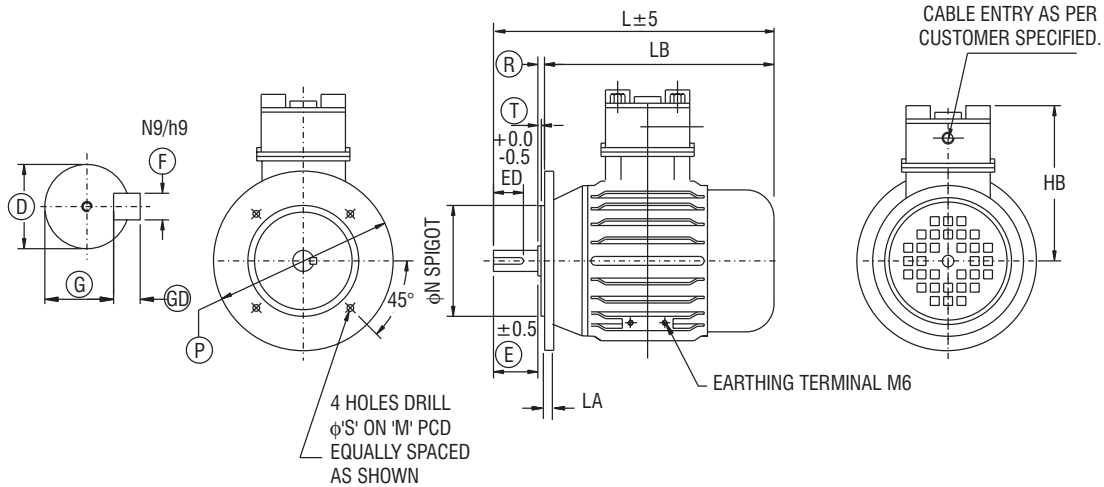

RINGED DIMENSIONS ARE AS PER IS:2223
ALL DIMENSIONS ARE IN mm

Frame	D	E	ED	F	GD	G	Y	AD	AC	L	MTol	NTol	P	S	T	LA	LB	HB
E80	19.009/ 18.996	40	27	6.00/ 5.97	6.00/ 5.97	15.5/ 15.3	M6X16	205	165	274	165.3/ 164.7	130.014/ 129.989	200	12	3.5	10	245	188

OUTLINE DIMENSION DRAWING FOR 3 PHASE SQUIRREL CAGE TEFC FLANGE MOUNTED FLAME PROOF INDUCTION MOTORS

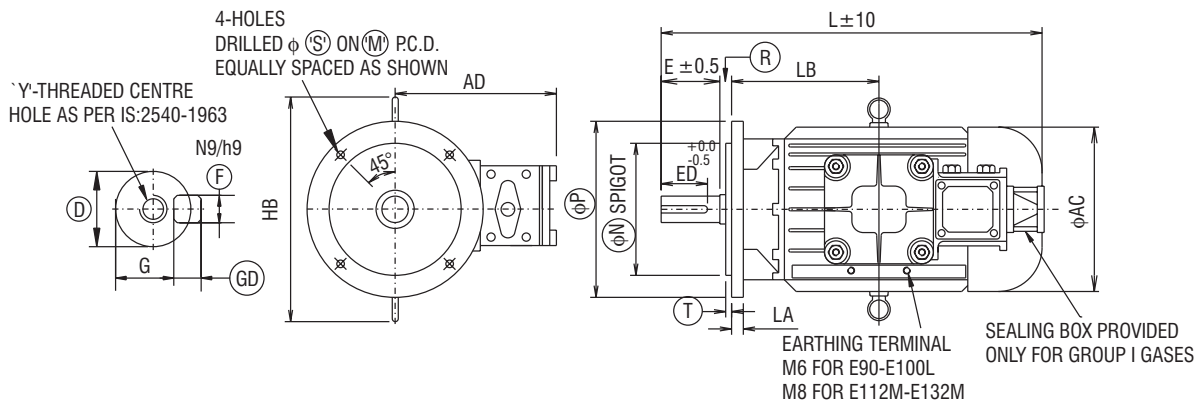

RINGED DIMENSIONS ARE AS PER IS:2223
ALL DIMENSIONS ARE IN mm

Frame	D	E	ED	F	GD	G	Y	AD	AC	L	MTol	NTol	P	S	T	LA	LB	HB
E90L	24.009/ 23.996	50	36	8.00/ 7.957	7.00/ 6.91	20.0/ 19.8	M8x19	240	210	380	165.3/ 164.7	130.014/ 129.989	200	12	3.5	10	137	300
E100L	28.009/ 27.996	60	44	8.00/ 7.957	7.0/ 6.91	24.0/ 23.8	M10X22	255	240	415	215.3/ 214.7	180.016/ 179.987	250	15	4	11	320	330
E112M	28.009/ 27.996	60	44	8.00/ 7.957	7.0/ 6.91	24.0/ 23.8	M10X22	270	270	425	215.3/ 214.7	180.016/ 179.987	250	15	4	11	345	350
E132M	38.018/ 37.996	80	60	10.0/ 9.957	8.0/ 7.91	33.0/ 32.8	M12X28	290	320	520	265.3/ 264.7	230.016/ 229.987	300	15	4	13	177	440



OUTLINE DIMENSION DRAWING FOR 3 PHASE SQUIRREL CAGE TEFC FLANGE MOUNTED FLAME PROOF INDUCTION MOTORS (4 POLE & UP FOR ALL FRAMES & 2 POLE & UPTO ND200L)

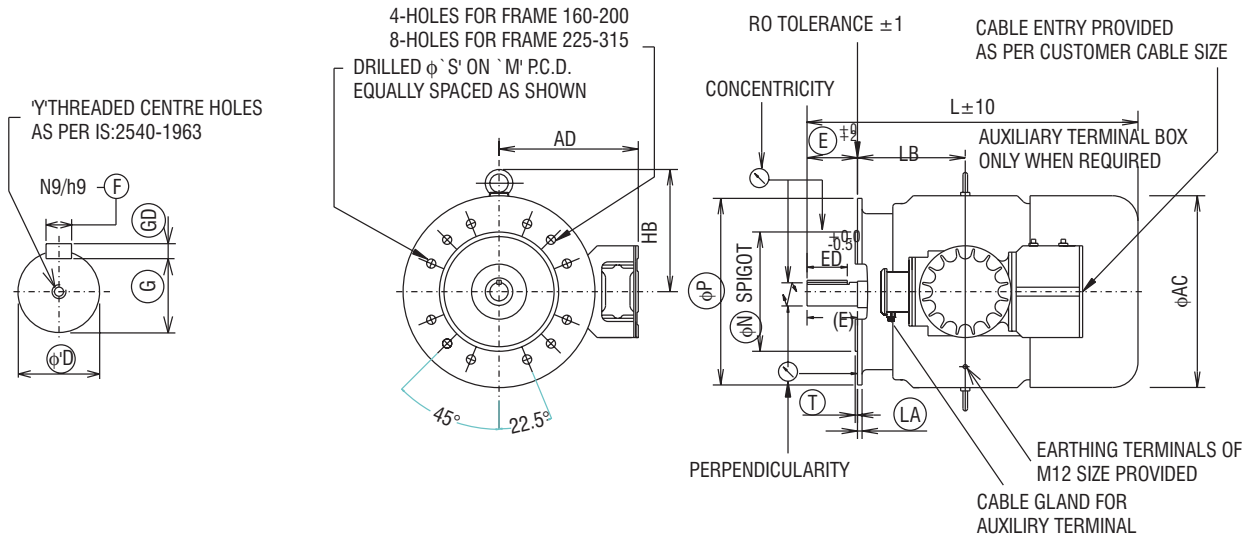

RINGED DIMENSIONS ARE AS PER IS:2223
ALL DIMENSIONS ARE IN mm

Frame	D	E	ED	F	GD	G	Y	AD	AC	L	MTol	NTol	P	S	T	LA	LB	HB
E160L	42.018 / 42.002	110	80	12.00 / 11.957	8.00 / 7.91	37.0 / 36.8	M16X32	345	320	655	300.5 / 299.5	250.016 / 249.987	350	19	5	18	235	220
E180L	48.018 / 48.002	110	80	14.00 / 13.957	9.00 / 8.91	42.5 / 42.3	M16X32	362	370	750	300.5 / 299.5	250.016 / 249.987	350	19	5	18	261	245
E200L	55.030 / 55.011	110	80	16.00 / 15.957	10.00 / 9.91	49.0 / 48.8	M20X40	400	435	790	350.5 / 349.5	300.016 / 299.984	400	19	5	18	286	280
E225S	60.030 / 60.011	140	110	18.00 / 17.957	11.00 / 10.91	53.0 / 52.8	M20X40	402	490	832	400.5 / 399.5	350.018 / 349.982	450	19	5	19	292	300
E225M	60.030 / 60.011	140	110	18.00 / 17.957	11.00 / 10.91	53.0 / 52.8	M20X40	402	490	857	400.5 / 399.5	350.018 / 349.982	450	19	5	19	305	300
E250M	65.030 / 65.011	140	110	18.00 / 17.957	11.00 / 10.91	58.0 / 57.8	M20X40	440	560	977	500.5 / 499.5	450.020 / 449.980	550	19	5	22	343	355
E280M	75.030 / 75.011	140	110	20.00 / 19.48	12.00 / 11.91	67.5 / 67.3	M20X40	476	620	1094	500.5 / 499.5	450.020 / 449.980	550	19	5	22	400	380
E315M	80.030 / 80.011	170	140	22.00 / 21.948	14.00 / 13.91	71.0 / 70.8	M20X40	516	705	1220	601.0 / 599.0	550.022 / 549.978	660	24	6	25	445	460

FLP Motors



OUTLINE DIMENSION DRAWING FOR 3 PHASE SQUIRREL CAGE TEFC FLANGE MOUNTED FLAME PROOF INDUCTION MOTORS (2 POLE)

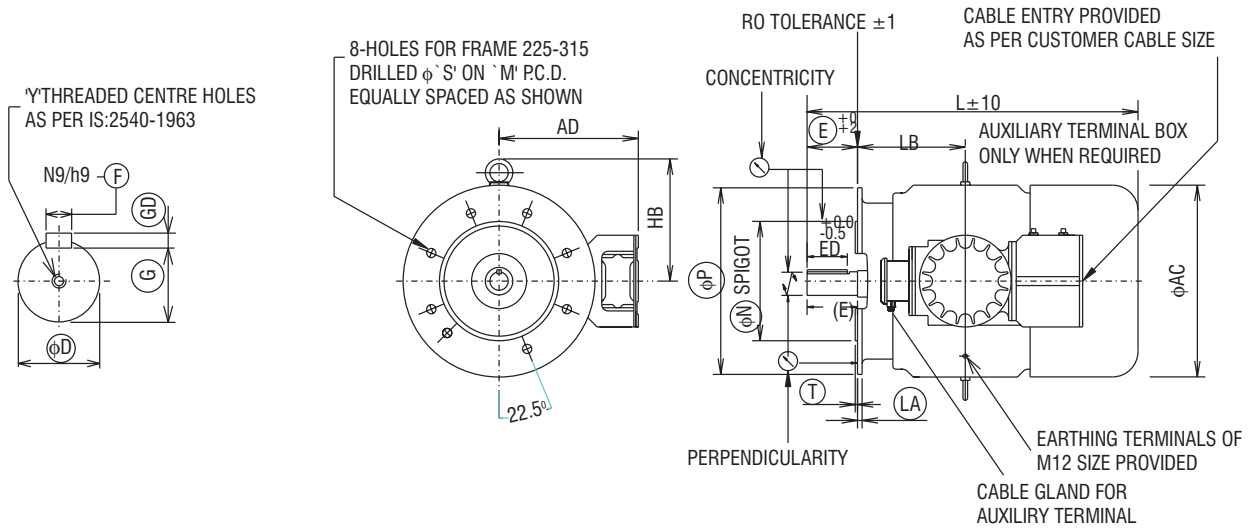

RINGED DIMENSIONS ARE AS PER IS:2223
ALL DIMENSIONS ARE IN mm

Frame	D	E	ED	F	GD	G	Y	AD	AC	L	MTol	NTol	P	S	T	LA	LB	HB
E225S	55.030 / 55.011	110	80	16.00 / 15.957	10.0 / 9.91	49.0 / 48.8	M20X40	402	490	802	400.5 / 399.5	350.018 / 349.982	450	19	5	19	292	300
E225M	55.030 / 55.011	110	80	16.00 / 15.957	10.0 / 9.91	49.0 / 48.8	M20X40	402	490	827	400.5 / 399.5	350.018 / 349.982	450	19	5	19	305	300
E250M	60.030 / 60.011	140	110	18.00 / 17.957	11.00 / 10.91	53.0 / 52.8	M20X40	440	560	977	500.5 / 499.5	450.020 / 449.980	550	19	5	22	343	355
E280M	65.030 / 65.011	140	110	18.00 / 17.957	11.00 / 10.91	58.0 / 57.8	M20X40	476	620	1094	500.5 / 499.5	450.020 / 449.980	550	19	5	22	400	380
E315M	65.030 / 65.011	140	110	18.00 / 17.957	11.00 / 10.91	58.0 / 57.8	M20X40	516	705	1190	601.0 / 599.0	550.022 / 549.978	660	24	6	25	445	460



OUTLINE DIMENSION DRAWING FOR 3 PHASE SQUIRREL CAGE TEFC FLANGE MOUNTED FLAME PROOF INDUCTION MOTOR.(FRAME : E315L)

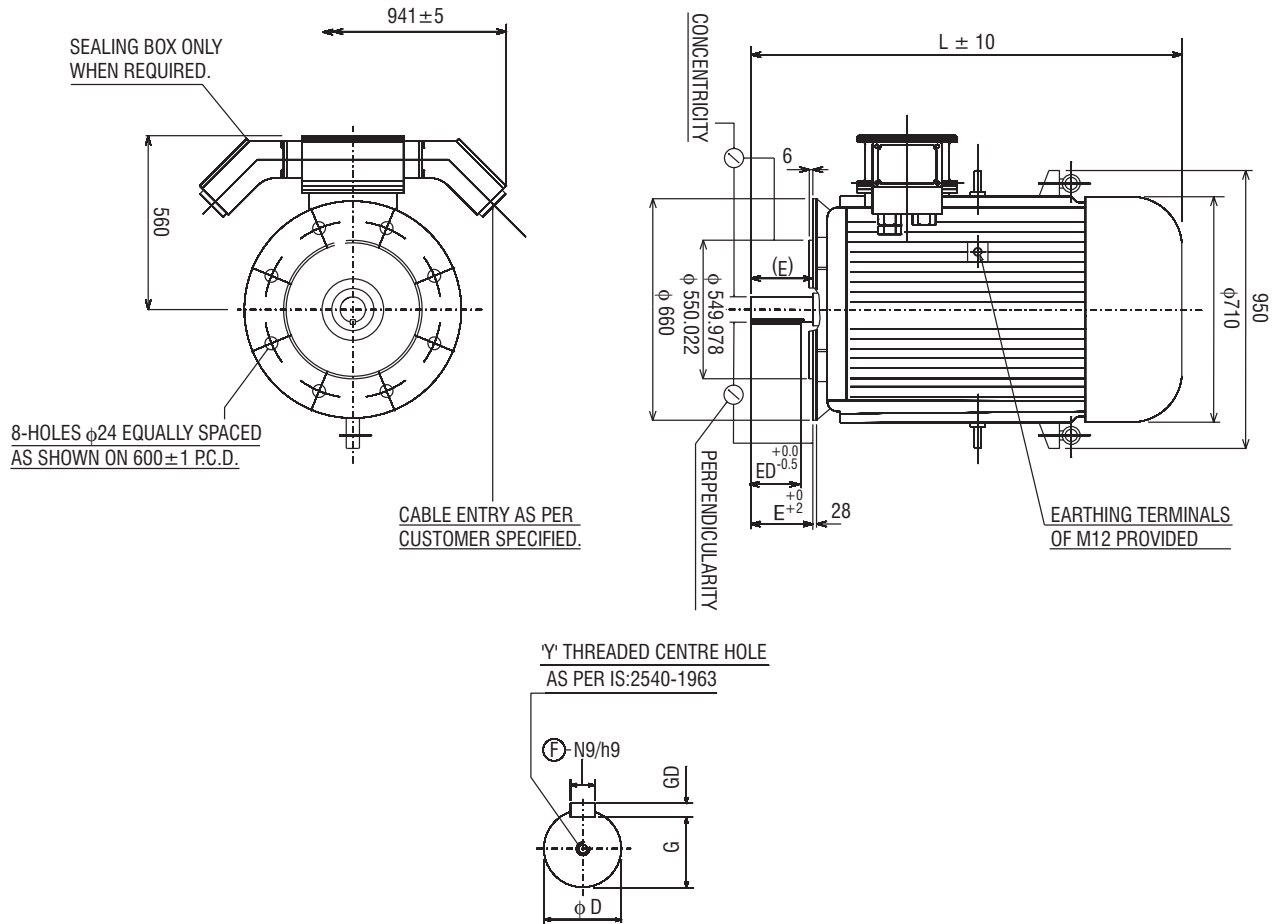

POLE	SHAFT AND KEY							
	D TOL.	E	ED	F TOL.	GD TOL.	G	Y	L
4P & UP	90.035/90.013	170	140	25.0/24.948	14.0/13.91	81.0/80.8	M24x50	1492
2	70.030/70.011	140	110	20.0/19.948	12.0/11.91	62.5/62.3	M20x40	1462